



Technology Solutions

TEK-FLUX 1400B

Insertion Electromagnetic Flowmeter



FLOW



www.tek-trol.com

Flow | Level | Temperature | Pressure | Valves | Analyzers | Accessories | TekValSys

Introduction

Tek-Flux 1400B Electromagnetic Flowmeters are used to measure the flow rate of a variety of conductive liquids. It functions according to the fundamental principle of Faraday's law of Electromagnetic Induction, which describes the relationship between an electrical conductor and the voltage it generates when moving within a magnetic field.

Measuring Principle

In an Electromagnetic Flowmeter, a magnetic field is generated by a pair of diametrically placed electrical coils mounted external to the flow tube. As the conductive liquid passes through this Electromagnetic field, an electrical voltage is induced in the liquid, which is directly proportional to its velocity. This induced voltage is perpendicular to the directions of both - the liquid flow and the Electromagnetic field.

A pair of diametrically placed electrodes mounted along the inner wall of the flow tube and in the direction of the induced voltage, sense this induced voltage. The sensed voltage is further processed by the Transmitter to indicate the flow rate and generate a standard output signal proportional to the measured flow rate.

Operation

The flux density of the Electromagnetic field and the distance between the Electrodes are constant for a given Flowmeter. The induced voltage is therefore only a function of the liquid velocity.

$$E = K.B.V.D$$

Where -

E = Induced voltage

B = Magnetic field strength

K = Flow tube (meter) constant

v = Mean flow velocity

D = Distance between the electrodes

And the volumetric flow is calculated as –

$$qv = (\pi \times D^2/4) \times v$$

Therefore,

$$qv = (\pi \times E \times D) / 4 K B$$

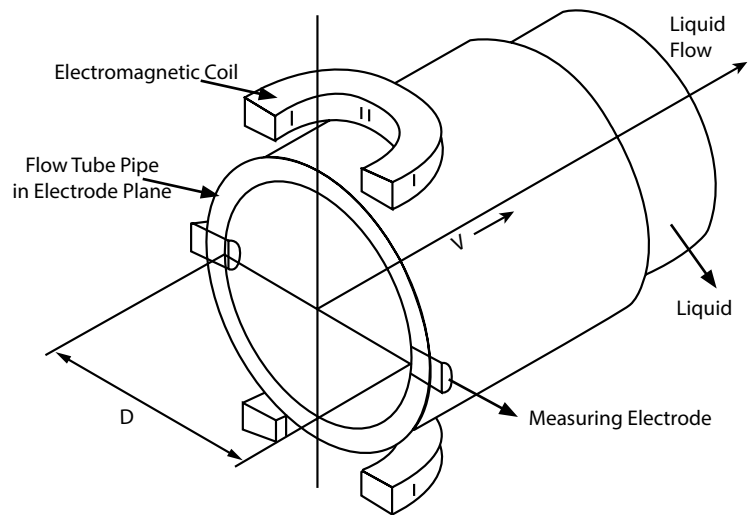

The induced voltage is not affected by the physical properties of the liquid like temperature, viscosity, pressure, density and conductivity, as long as the conductivity of the measured liquid is above a minimum threshold.

Features

- Adjustable depth
- Can be used in pipes from 4" to 80"
- Comes with isolation valve
- No moving parts
- Multiple signal outputs

Applications

Tek-Flux 1400B can be successfully deployed in a wide range of industrial liquid flow measurement applications. The major industry sectors include, but not limited to:

- Chemical and Process Industries
- Pharmaceutical Industries
- Sugar and Beverage Industries
- Mining and Dredging Industries
- Water and Waste Water Management

Dimensional Drawing

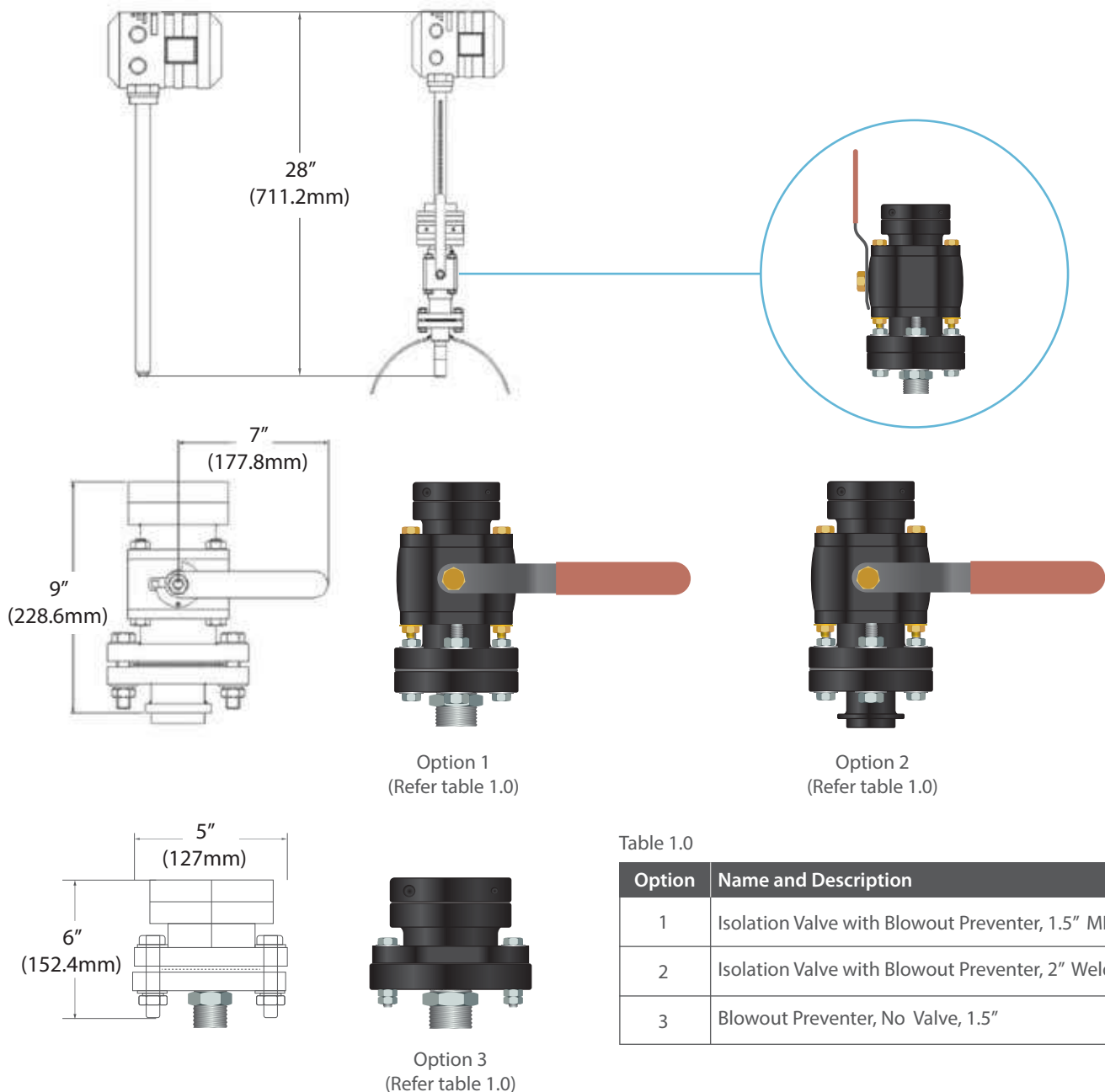
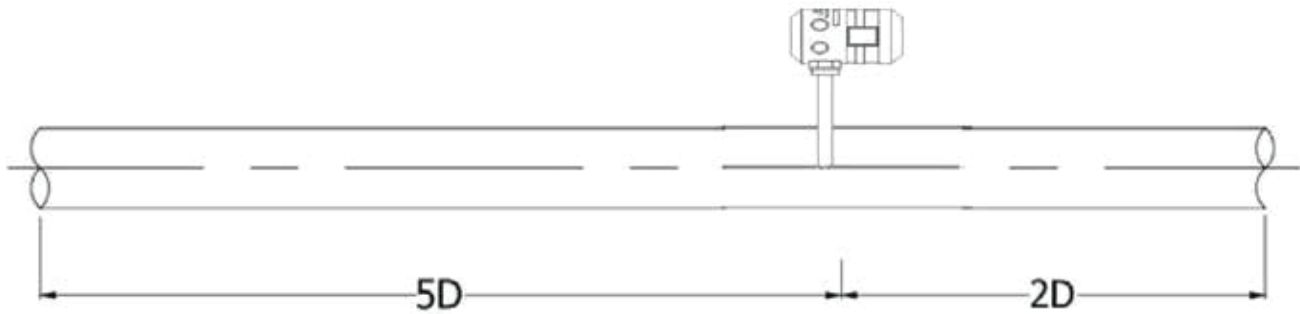
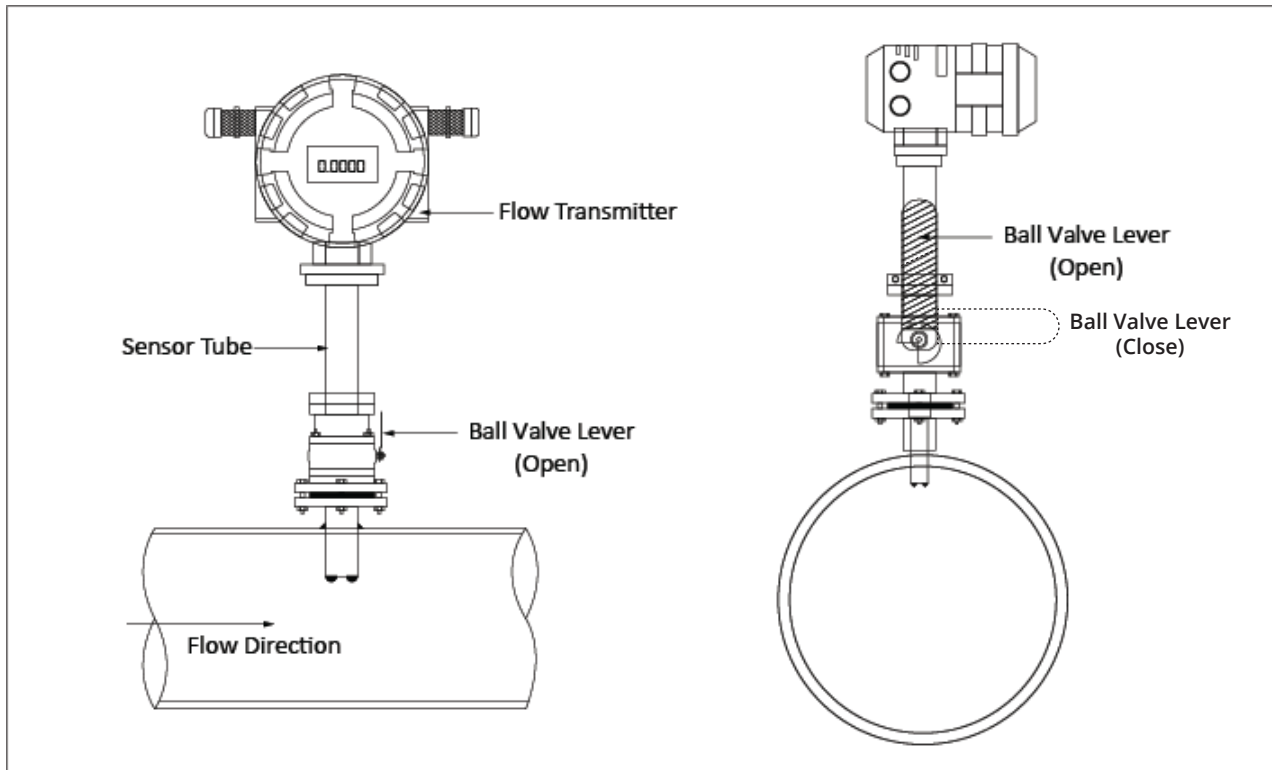

Table 1.0

Option	Name and Description
1	Isolation Valve with Blowout Preventer, 1.5" MNPT
2	Isolation Valve with Blowout Preventer, 2" Weldolet
3	Blowout Preventer, No Valve, 1.5"

Protecting the Transmitter



At flowmeter upst ream, there should be straight pipe no less than $5D$ and no less than $2D$ at flowmeter downstream. (D is the inner diameter of flowmeter)

Specifications

Nominal Diameter	4" to 80"	
Working Process Pressure	250 psi	
Electrode Material	Hastelloy C	
Wetted Material	316 SS, Hastelloy C, PTFE	
Flow Sensor Rating	IP66, NEMA4X	
Minimum Liquid Conductivity	10 μ siemens	
Accuracy of Measured Value	$\pm 1\%$ of span	
Repeatability	$\pm 0.2\%$ of Span	
Measuring Range	0.65 to 39 ft/sec Bi-directional	
Display Version	Integral	
Display Type	16 characters x 2 row LCD, 5 Digit Flow rate and 8 Digit Totalizer	
Units	Flow Rate	Totalizer
	LPS, LPM, LPH, LPD	L, MI, m ³
	MIps, MIpm, MIph, MIpd	MI
	cc/s, cc/m, cc/h, cc/d	L, MI, cc, m ³
	m ³ /s, m ³ /m, m ³ /h, m ³ /d	L, MI, m ³
	kg/s, kg/m, kg/h, kg/d	kg, t
	t/s, t/m, t/h, t/d	T
	gps, gpm, gph, gpd	G, ft ³
	Mgps, Mgpm, Mgph, Mgpd	Mg
	Igps, Igpm, Igph, Igpd	Ig, ft ³
	IMgps, IMgpm, IMgph, IMgpd	IMg
	ft ³ /s, ft ³ /m, ft ³ /h, ft ³ /d	g, Ig, ft ³
	lb/s, lb/m, lb/h, lb/d	lb
Current Output	4 to 20 mA and Pulse	
Digital Output	Modbus RS485 or HART	
Power Supply	18 to 60 VDC or 80 to 300 VAC	
Electrical Connection	1/2" NPT	
Operating Temperature	-20°F to 250°F (-28°C to 120°C)	
Process Connection	1.5" MNPT or 2" Weldolet	

Sensor Installation

The Flowmeter can be installed at any arbitrary location in the pipeline as long as the installation requirements are satisfied. At the same time, care should be exercised when selecting the installation site to assure that moisture cannot enter into the connection area.

- A ball valve assembly with Weld Neck Flange will be supplied in advance.
- A hole of 1.96" diameter is to be made on the pipe line. The Weld Neck Flange is to be welded into the Pipe Line for Flowmeter installation.
- Put a gasket between Weld neck Flange and Ball Valve Assembly.
- Mount Ball Valve Assembly on the Weld Neck Flange by aligning Weld Neck Flange and Ball Valve Assembly Bottom Flange. Ensure Ball Valve Lever Alignment is with respected to the Flow direction as shown in the figure.
- The Ball Valve Assembly Mounting Bolts are provided (M 10 X 3.93") The mounting bolts are to be tightened. Follow diametrically opposite tightening Sequence.
- Loosen the Collete Clamping Screws provided on the periphery of collect at the Top of Ball Valve Assembly.
- According to the theory of velocity profiles for fully developed turbulent flow in the pipe line, the average velocity point is located at a distance of $1/8 D$ from the pipe wall where D is the internal pipe diameter.
- We insert up to 10% of Pipe Diameter.
- Before Sensor is inserted, the insertion length is marked on the Sensor.
 - a) Measure the length of Assembly from Pipe Surface to Collete Top. (Say X)
 - b) Say Insertion Length is Y .
 - c) Say Pipe Thickness is Z .
 - d) Now mark the length of $X + Y + Z$ starting from Electrodes and up.
- Now open Ball Valve lever fully. Slowly insert the Flow meter's Sensor, passing through the hole.
- Up to the length marked on the Sensor. The Flow Transmitter direction should be as per the drawing.
- Once, the Insertion Length is achieved, tighten the Collete Clamping Screws.
- For the Flowmeter installation in a pit, for proper installation, commissioning and maintenance of the Flowmeter, the pit dimensions have to be at least 6.5ft X 6.5ft.
- Kindly ensure that the pit is covered with the protective cover. The pit should be waterproof so that in rainy season it should not get flooded or submerged in water.

Transmitter Installation

Integral Type Transmitter

- In case of an Integral Type Flowmeter, the Transmitter comes pre-mounted atop the Flow Sensor and therefore gets physically installed along with the Flow Sensor/sensor.
- The images below show the Integral Type Transmitter mounted on the Flow Sensor.

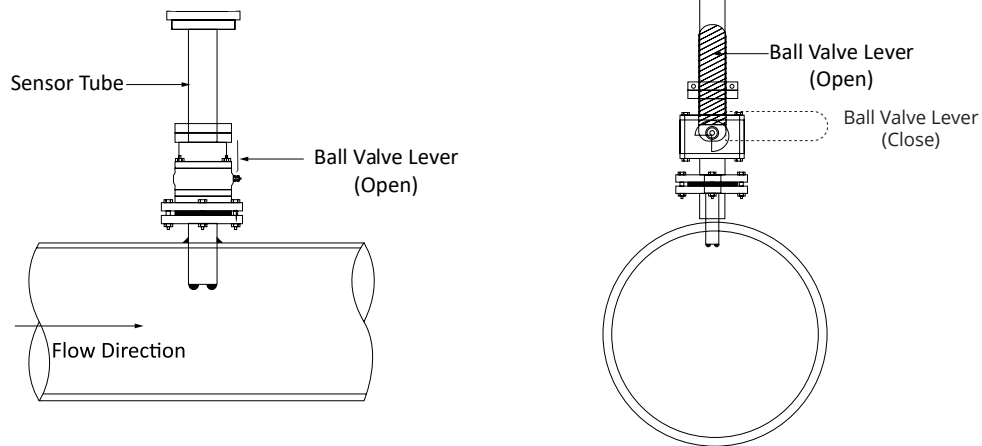

Protecting the Transmitter

Provide a weather-shade/ canopy to protect the Transmitter from direct exposure to sunlight, rain or any other dropping fluids. This will help enhance the useful life of the Transmitter.

Electrical Connection

Instructions for Connecting Cables

Always use cables of the following specifications.

- Power: 3 core, 0.039 inch², PVC/ PTFE sheathed cable
- Current Output: 2 core, 0.039 inch², PVC/PTFE sheathed cable
- Coil and Electrodes (in case of Remote Type Flowmeter): as supplied with Flow Sensor

Model Chart

Example	Tek-Flux 1400B	1	H	HC	1	1	T	#	Tek-Flux 1400B-1-H-HC-1-1-T-1
Series	Tek-Flux 1400B								Insertion Electromagnetic Flowmeter
Transmitter		1							Direct Mount
Output			S H						4-20mA, Pulse, Modbus RS485 4-20mA, Pulse, HART
Electrodes				HC					Hastelloy C
Insertion Length					1				20" Probe
Power Supply						1 2			18 - 28 VDC 80 - 300 VAC/VDC
Electrode Cap							T		PTFE
Valve Options								1 2 3	Isolation Valve with Blowout Preventer, 1.5" MNPT Process Connection Isolation Valve with Blowout Preventer, 2" Weldolet Process Connection Blowout Preventer, No Valve, 1.5" MNPT Process Connection

Popular Model

Model	Description
1400B-1-H-HC-1-1-T-1	Insertion Electromagnetic Flow Meter, 20" Probe

Customer Service and Support



TEKMATION LLC reserves the right to change the designs and/or materials of its products without notice. The contents of this publication are the property of TEKMATON and cannot be reproduced by any other party without written permission. All rights reserved. Copyright © 2016 TEKMATON LLC
DOC# /TEK/PO/CAT/200407/1400B/04
TEKMATION LLC



www.tek-trol.com

Tek-Trol is a fully owned subsidiary of TEKMATON LLC. We offer our customers a comprehensive range of products and solutions for process, power, and oil and gas industries. Tek-Trol provides process measurement and control products for Flow, Level, Temperature and Pressure Measurement, Control Valves and Analyzer systems. We are present in 15 locations globally and are known for our knowledge, innovative solutions, reliable products, and global presence.

Tek-Trol LLC

796 Tek Drive Crystal Lake, IL 60014 USA
Tel: +1 847 857 6076 , +1 847 655 7428 Fax: +1 847 655 6147
Email: tektrol@tek-trol.com
www.tek-trol.com