



Technology Solutions

TEK-BAR 3120C

Tri-Clamp Gauge Pressure Transmitter



PRESSURE



Introduction

Tek-Bar 3120C Tri-Clamp Gauge Pressure Transmitter uses the world's advance silicon pressure sensor technology and state of the art encapsulation technology. This is a high performance pressure transmitter with HART communication protocol and is used to measure gauge pressure. It is used to measure liquid, gas, or steam flow as well as liquid level and density of medium. It has a high accuracy of up to 0.2% of URL and has IP66 water-proof protection.

Measuring Principle

The Tri-Clamp Gauge Pressure Transmitter works on the principle of mono silicon technology. The pressure sensor of the transmitter is located on the top of the metal body, away from the service fluid. This enables mechanical and thermal isolation of the sensor from the fluid in service.

When pressure is applied on the diaphragm and the silicon piezoelectric sensor, they become stressed and undergo a change in voltage resistance. This change in resistance is directly proportional to the applied pressure, which is transferred to the transmitter body using lead wires.

Built on semiconductor technology, the resistance change (piezoelectric effect) is notably higher than exhibited in standard strain gauge. Therefore, the sensitivity of mono-crystalline sensors is higher than the sensitivity of most other types.

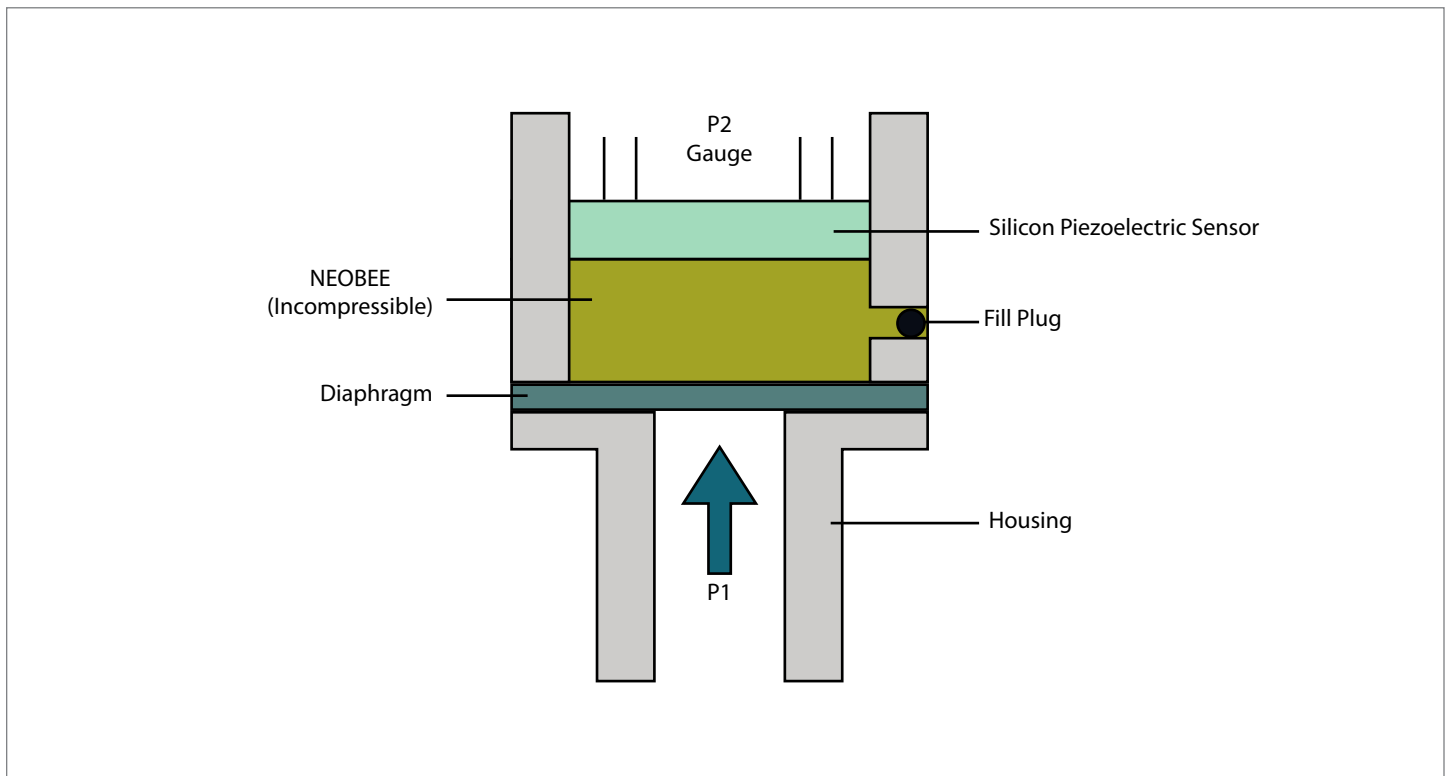

Features

- Digital communication HART protocol
- High accuracy up to $\pm 0.2\%$
- Various Output: 4-20 mA, digital signals with HART® Communication (Modbus RS485)
- Multiple temperature and linearity compensation to improve accuracy
- Fully-sealed and fully isolated silicon pressure sensor
- Superior stainless steel process flange
- Dual diaphragm overload protection, can easily cope with overload tests
- 355° rotation display module

Applications

- Food Processing
- Distilleries
- Food Processing
- Pulp and Paper
- Dairy

Dimensional Drawing

Dimension with display

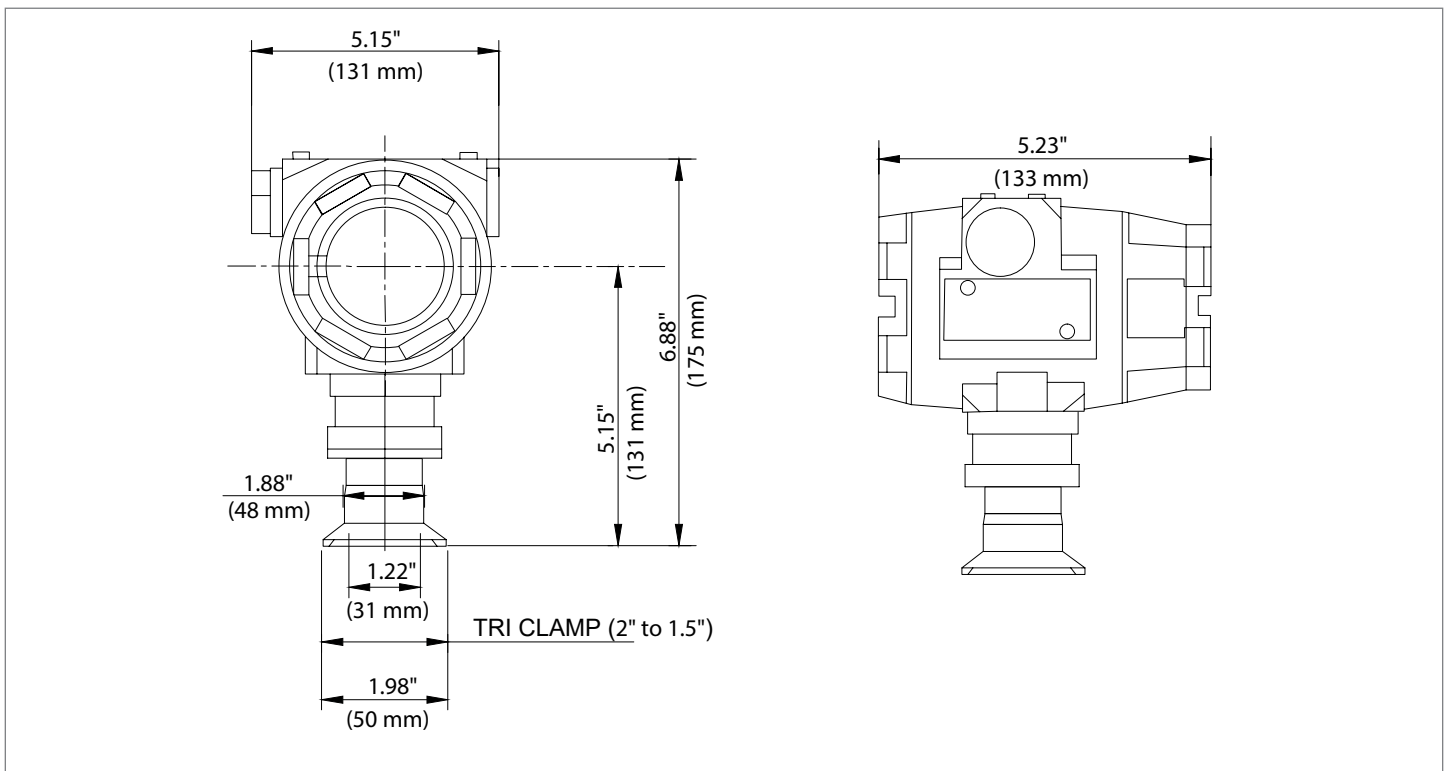

Specifications

Process Medium	All fluids compatible with wetted parts
Pressure Type	Gauge Pressure
Process Connection	1-½" Tri-Clamp or 2" Tri-Clamp
Wetted Materials	316L SS
Ranges	5.8 psig to 300 psig
Accuracy	±0.2% F.S.
Stability	±0.2% URL/5 years
Working Temperature	-40 °F to 185 °F (-40 °C to 85 °C)
Insulation Resistance	≥20 M Ω at 100 VDC
Mounting Position Effect	Apply to any position. Max value lower than 1.6 w.c. (400 Pa) can be corrected by zero clearing function
Working Humidity	5-100% RH
Net Weight	Approx 3.43 lbs (1.55 Kg)
Protection class	IP66
Output Signal	4 mA to 20 mA with HART (Optional Modbus RS485)

Measuring Range and Limit

Nominal Value	Smallest Calibrated Span	Lower Range Limit (LRL)	Upper Range Limit (URL)	Overload Limit*
5.8 psi	8 in.WC	-14.5 psi	5.8 psi	145 psig
36 psi	2 psi	-14.5 psi	36 psi	580 psig
145 psi	7.25 psi	-14.5 psi	145 psi	870 psig
300 psi	15 psi	-14.5 psi	300 psi	1500 psig

The unit of the measuring range above can be converted. Provide other measuring range according to requirements. Adjust requirements: lower range value (LRV) and upper low value (ULV) can be adjusted within the scope of the upper and lower range limit, minimum measuring ranges $\leq |URV - LRV| \leq$ maximum measuring ranges

* Over voltage value: depending on the pressure value of the weakest part

Vibration Effects

Vibration Resistance	According to IEC60068-2-6, 10g RMS (25-2000Hz)
Impact Resistance	According to IEC60068-2-6, 500g/1ms

Damping Time

Total damping time constant	Equal to the sum of damping time of amplifier and sensor capsule
Damping time of amplifier	0 -100 s adjustable
Response Time	≤ 0.2 s
Start-up after power off	≤ 6 s

Power Supply	
Standard/flame proof	10.5-55 VDC
Load resistance	0-2119 Ω for working condition, 250- 600 Ω for HART protocol
Max. Transmission distance	3281 ft
Power consumption	\leq 500 mW at 24 VDC, 20.8 mA

Installation Guidelines

- Ensure that the operating staff handling the pressure instrument is professionally trained.
- Keep impulse piping as short as possible and maintain the impulse lines at same temperature.
- Avoid sediment deposition in impulse piping.
- In case of liquid applications, vent all gas from piping legs, and avoid trapped air.
- Ensure there are no pressure leakage points in the connection.
- Maintain equal leg of head pressure on both legs of impulse piping.
- Isolate the transmitter body from corrosive or hot process medium.
- Avoid conditions that might allow freezing of process fluid and block the pipe.

Model Chart

Example	Tek-Bar 3120C-G	3	WP	1	SS	1	BA	Tek-Bar 3120C-G-3-WP-1-SS-1-BA
Series	Tek-Bar 3120C-G							Tri-Clamp Gauge Pressure Transmitter
Range Options		1 2 3 4						0 to 5.8 psig (40:1 Turndown, Adj. Range: -14.5 to 5.8 psig) 0 to 36 psig (40:1 Turndown, Adj. Range: -14.5 to 36 psig) 0 to 145 psig (40:1 Turndown, Adj. Range: -14.5 to 145 psig) 0 to 300 psig (40:1 Turndown, Adj. Range: -14.5 to 300 psig)
Approval Rating			WP					General Purpose NEMA 4X/IP66
Process Connections				1 2				2" Tri-Clamp 1½" Tri-Clamp
Diaphragm Material					SS			SS 316L (Only available with Tri-Clamp)
Electrical Connections						1		½" NPT Female
Options							CC FC BA TAG	Custom Calibration with 5 point Calibration Certificate Factory Configuration, No Certificate Stainless Steel Bracket (Angle type) with SST Bolts Custom Etching of the Name Plate (Must specify on P.O.)

Popular Models

Model Number	Description
3120C-G-1-WP-1-SS-1	Tri-Clamp Gauge Pressure Transmitter, 0-5.8 psig, LCD
3120C-G-2-WP-1-SS-1	Tri-Clamp Gauge Pressure Transmitter, 0-36 psig, LCD
3120C-G-3-WP-1-SS-1	Tri-Clamp Gauge Pressure Transmitter, 0-145 psig, LCD
3120C-G-4-WP-1-SS-1	Tri-Clamp Gauge Pressure Transmitter, 0-300 psig, LCD

Customer Service & Support



TEK-TROL LLC reserves the right to change the designs and/or materials of its products without notice. The contents of this publication are the property of TEK-TROL LLC and cannot be reproduced by any other party without written permission. All rights reserved. Copyright © 2020 TEK-TROL LLC
TEK-TROL LLC
DOC # TEKPO/CAT/200626/3120C/02.1



www.tek-trol.com

Tek-Trol LLC

796 Tek Drive Crystal Lake, IL 60014,
USA
Sales: +1 847-655-7428

Tek-Trol Solutions BV

Florijnstraat 18, 4879 AH Etten-Leur,
Netherlands
Sales: +31 76-2031908

Tek-Trol Middle East FZE

SAIF Zone, Y1-067, PO BOX No.
21125, Sharjah, UAE
Sales: +971-6526-8344

Support: +1 847-857-6076

Email: tektrol@tek-trol.com

www.tek-trol.com

Tek-Trol is a fully owned subsidiary of TEKMATON LLC. We offer our customers a comprehensive range of products and solutions for process, power and oil & gas industries. Tek-Trol provides process measurement and control products for Flow, Level, Temperature & Pressure measurement, Control valves & Analyzer systems. We are present in 15 locations globally and are known for our knowledge, innovative solutions, reliable products and global presence.